

112Gb/s QSFP28 ER4 40km Transceiver SLT0QPE4112LT31x

Features

- 4 channels full-duplex transceiver modules
- Transmission data rate up to 28.05Gbps per channel
- Built-in 4-channel Clock and Data Recovery (CDR) in TX and RX
- 4-lane EMLTOSA and 4-lane APD
- Up to 40km reach for G.652 SMF
- Hot pluggable 38 pin electrical interface
- QSFP28 MSA compliant
- Duplex LC optical receptacle
- RoHS-10 compliant and lead-free
- Excellent EMI performance
- Single +3.3V power supply
- Maximum power consumption 5W
- Operating case temperature 0°C to +70°C

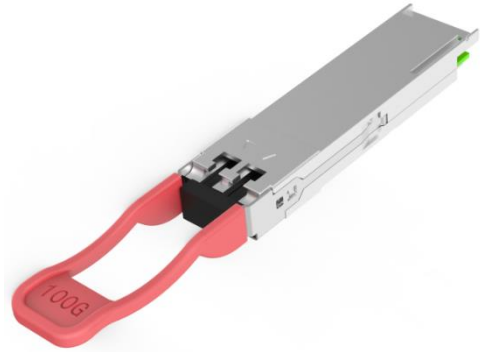

Applications

- 100GBASE-ER4 Ethernet
- Telecom networking
- 100G OTU4

Order Information

Part Number	Data Rate (Gb/s)	Wavelength (nm)	Transmission Distance(km)	Temperature (°C) (Operating Case)
SLT0QPE4112GL31C	103.1/112	1295.56, 1300.05	40	0~70
SLT0QPE4112GL31I	103.1/112	1304.58, 1309.14	40	-40~85

Description

SLT0QPE4112GL31x is designed for 40km optical communication applications. This module contains 4-lane EML optical transmitter, 4-lane optical receiver and module management block including 2 wire serial interfaces. The optical signals are multiplexed to a single-mode fiber through an industry standard LC connector.

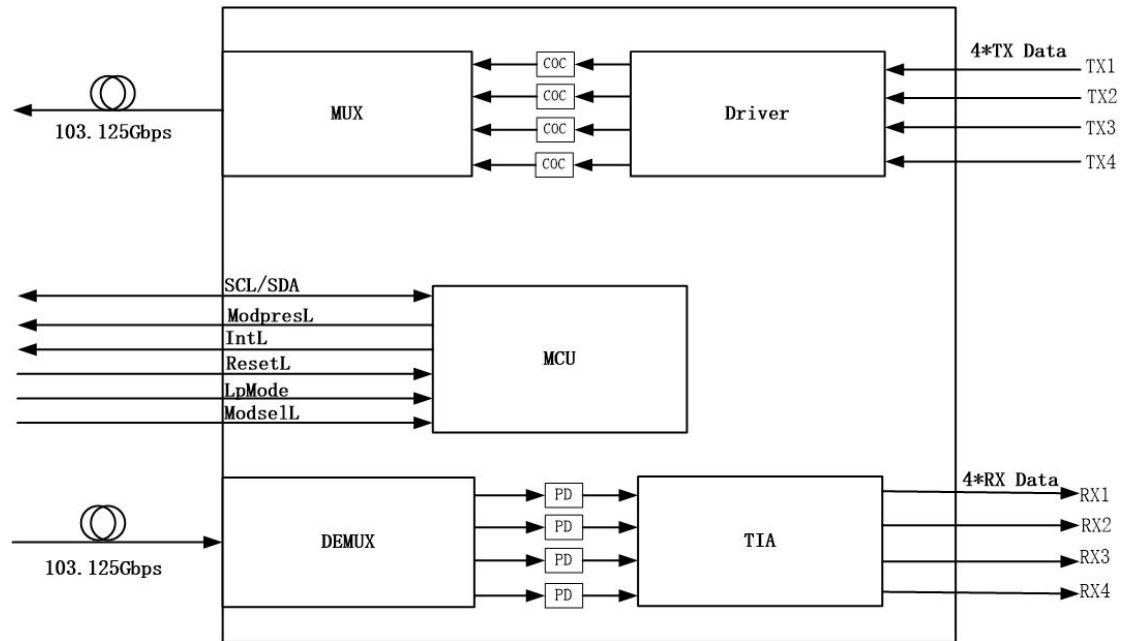

Absolute Maximum Ratings

It has to be noted that the operation in excess of any individual absolute maximum ratings might cause permanent damage to this module.

Parameter	Symbol	Min.	Typical	Max.	Unit	Notes
Supply Voltage	VCC3	-0.5	-	+3.6	V	
Storage Temperature	T _s	-40	-	+85	°C	
Operating Humidity	RH	+5	-	+85	%	1
Receiver Damage Threshold per Lane	P _{IND}	-3	-	-	dBm	

Note: 1 No condensation

Recommended Operating Conditions

Parameter	Symbol	Min.	Typical	Max.	Unit	Notes
Operating Case Temperature	TC	-40	-	+85	°C	
Power Supply Voltage	Vcc	3.14	3.3	3.47	V	
Power Dissipation	Pd	-	-	5	W	

Data Rate, each Lane	BR		25.78125	28.05	Gbps	
Link Distance (SMF)	D			40	km	1

Notes:

1. Depending on actual fiber loss/km (link distance specified is for fiber insertion loss of 0.35dB/km)

Pin Assignment and Pin Description

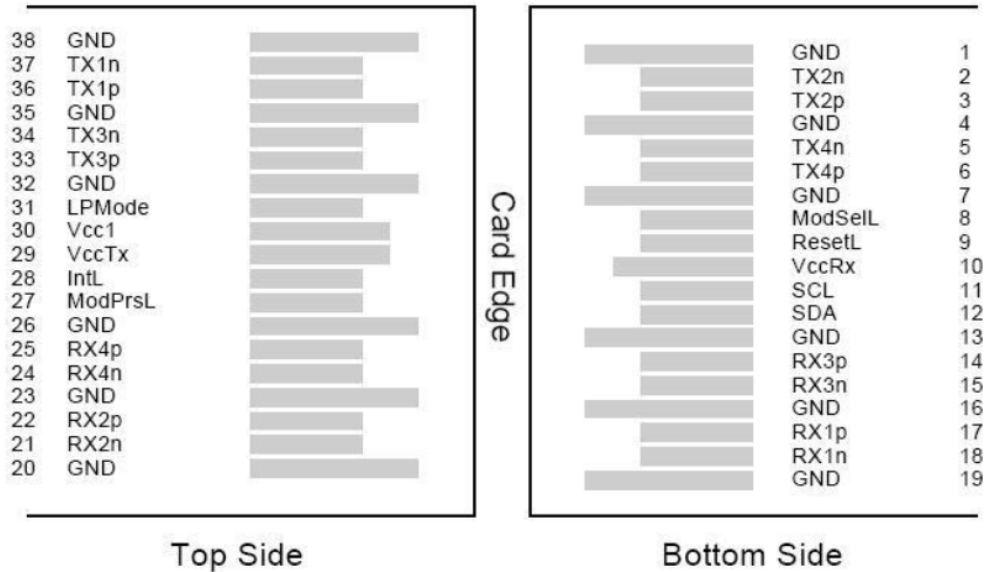

Figure1. Diagram of host board connector block pin numbers and names

Pin	Symbol	Name/Description	Notes
1	GND	Transmitter Ground (Common with Receiver Ground)	1
2	Tx2n	Transmitter Inverted Data Input	
3	Tx2p	Transmitter Non-Inverted Data Input	
4	GND	Transmitter Ground (Common with Receiver Ground)	1
5	Tx4n	Transmitter Inverted Data Input	
6	Tx4p	Transmitter Non-Inverted Data Input	
7	GND	Transmitter Ground (Common with Receiver Ground)	1
8	ModSelL	Module Select	
9	ResetL	Module Reset	

10	VccRx	3.3V Power Supply Receiver	2
11	SCL	2-Wire serial Interface Clock	
12	SDA	2-Wire serial Interface Data	
13	GND	Transmitter Ground (Common with Receiver Ground)	
14	Rx3p	Receiver Non-Inverted Data Output	
15	Rx3n	Receiver Inverted Data Output	
16	GND	Transmitter Ground (Common with Receiver Ground)	1
17	Rx1p	Receiver Non-Inverted Data Output	
18	Rx1n	Receiver Inverted Data Output	
19	GND	Transmitter Ground (Common with Receiver Ground)	1
20	GND	Transmitter Ground (Common with Receiver Ground)	1
21	Rx2n	Receiver Inverted Data Output	
22	Rx2p	Receiver Non-Inverted Data Output	
23	GND	Transmitter Ground (Common with Receiver Ground)	1
24	Rx4n	Receiver Inverted Data Output	1
25	Rx4p	Receiver Non-Inverted Data Output	
26	GND	Transmitter Ground (Common with Receiver Ground)	1
27	ModPrsl	Module Present	
28	IntL	Interrupt	
29	VccTx	3.3V power supply transmitter	2
30	Vcc1	3.3V power supply	2
31	LPMODE	Low Power Mode	
32	GND	Transmitter Ground (Common with Receiver Ground)	1
33	Tx3p	Transmitter Non-Inverted Data Input	
34	Tx3n	Transmitter Inverted Data Input	

35	GND	Transmitter Ground (Common with Receiver Ground)	1
36	Tx1p	Transmitter Non-Inverted Data Input	
37	Tx1n	Transmitter Inverted Data Input	
38	GND	Transmitter Ground (Common with Receiver Ground)	1

Notes:

1. GND is the symbol for signal and supply (power) common for QSFP28 modules. All are common within the QSFP28 module and all module voltages are referenced to this potential unless otherwise noted. Connect these directly to the host board signal common ground plane.
2. VccRx, VccI and VccTx are the receiving and transmission power suppliers and shall be applied concurrently. Recommended host board power supply filtering is shown below. Vcc Rx, VccI and Vcc Tx may be internally connected within the QSFP28 transceiver module in any combination. The connector pins are each rated for a maximum current of 1000mA.

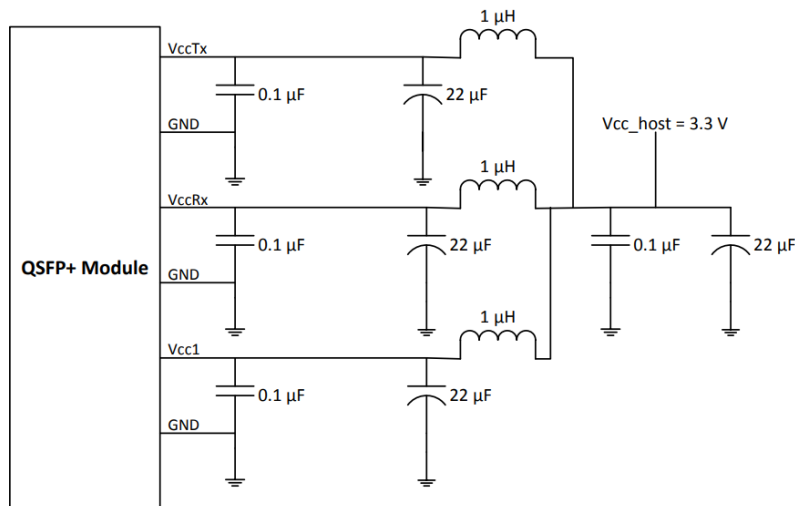

Figure2. RECOMMENDED HOST BOARD POWER SUPPLY FILTERING

Electrical Characteristics

The following electrical characteristics are defined over the Recommended Operating Environment unless otherwise specified.

Parameter	Symbol	Min.	Typ.	Max	Unit	Notes
Power Consumption	p			5	W	
Supply Current	Icc			1440	mA	
Transmitter (each Lane)						
Input differential impedance	Rin		100		Ω	

Differential Termination Mismatch				10	%	
Differential Data Input Amplitude	V _{in} , PP	180		1000	mV	
LPMode, Reset and ModSelL	V _{IL}	-0.3		0.8	V	
	V _{IH}	2		V _{cc} +0.3	V	
Receiver						
Differential Data Output Amplitude	V _{out} , PP	400	600	800	mV	
Differential Termination Mismatch				10	%	
Transition Time, 20 to 80%		9.5			ps	
ModPrsL and IntL	V _{OL}	0		0.4	V	
	V _{OH}	V _{cc} -0.5		V _{cc} +0.3	V	

Optical Characteristics

The following optical characteristics are defined over the Recommended Operating Environment unless otherwise specified.

Parameter	Symbol	Min.	Typical	Max	Unit	Notes
Transmitter						
Lane wavelength (range)	L0	1294.53	1295.56	1296.59	nm	
	L1	1299.02	1300.05	1301.09	nm	
	L2	1303.54	1304.58	1305.63	nm	
	L3	1308.09	1309.14	1310.19	nm	
Signaling rate, each lane			25.78125	28.05	Gb/s	
Side-mode suppression ratio	SMSR	30				
Total launch power	PT			10.5	dBm	
Average launch power, each lane	P _{avg}	-2.9		4.5	dBm	
Extinction Ratio	ER	8			dB	
TDP, each lane	TDP			2.5	dB	

Difference in Launch Power between any Two Lanes (OMA)	Ptx,diff			3.6	dB	
Average launch power of OFF transmitter, each lane	Poff			-30	dBm	
Transmitter reflectance	R _T			-12	dB	
RIN ₂₀ OMA	RIN			-130	dB/Hz	
Optical Return Loss Tolerance	TOL			20	dB	
Receiver						
Signaling rate, each lane			25.78125	28.05	Gb/s	
Average Receive Power, each Lane		-20		-4.9	dBm	
Input Saturation Power, each Lane				-4.9	dBm	
Receiver reflectance				-26	dB	
Receiver sensitivity, each lane	SEN1			-16.65	dBm	1
	SEN2			-20.5	dBm	2
LOS Assert	LOSA	-35			dBm	
LOS Deassert	LOSD			-22	dBm	
LOS Hysteresis	LOSH	0.5			dB	

Notes:

1. Measured @25.78125Gbps, ER=3.5dB, BER=<1E-12, PRBS=2³¹-1
2. Measured @28.05Gbps, ER=3.5dB, BER=<5E-5, PRBS=2³¹-1

Digital Diagnostic Functions

The following digital diagnostic characteristics are defined over the normal operating conditions unless otherwise specified.

Parameter	Symbol	Min.	Max	Unit	Range
Temperature monitor absolute error	DMI_Temp	-3	3	°C	0~75C
Supply voltage monitor absolute error	DMI_VCC	-3	3	%	0~Vcc

RX power monitor absolute error	DMI_RX	-3	3	dB	-7~-30dBm
Bias current monitor error	DMI_bias	-10	10	%	0~120mA
TX power monitor absolute error	DMI_TX	-3	3	dB	1~6dBm

Monitoring Specification

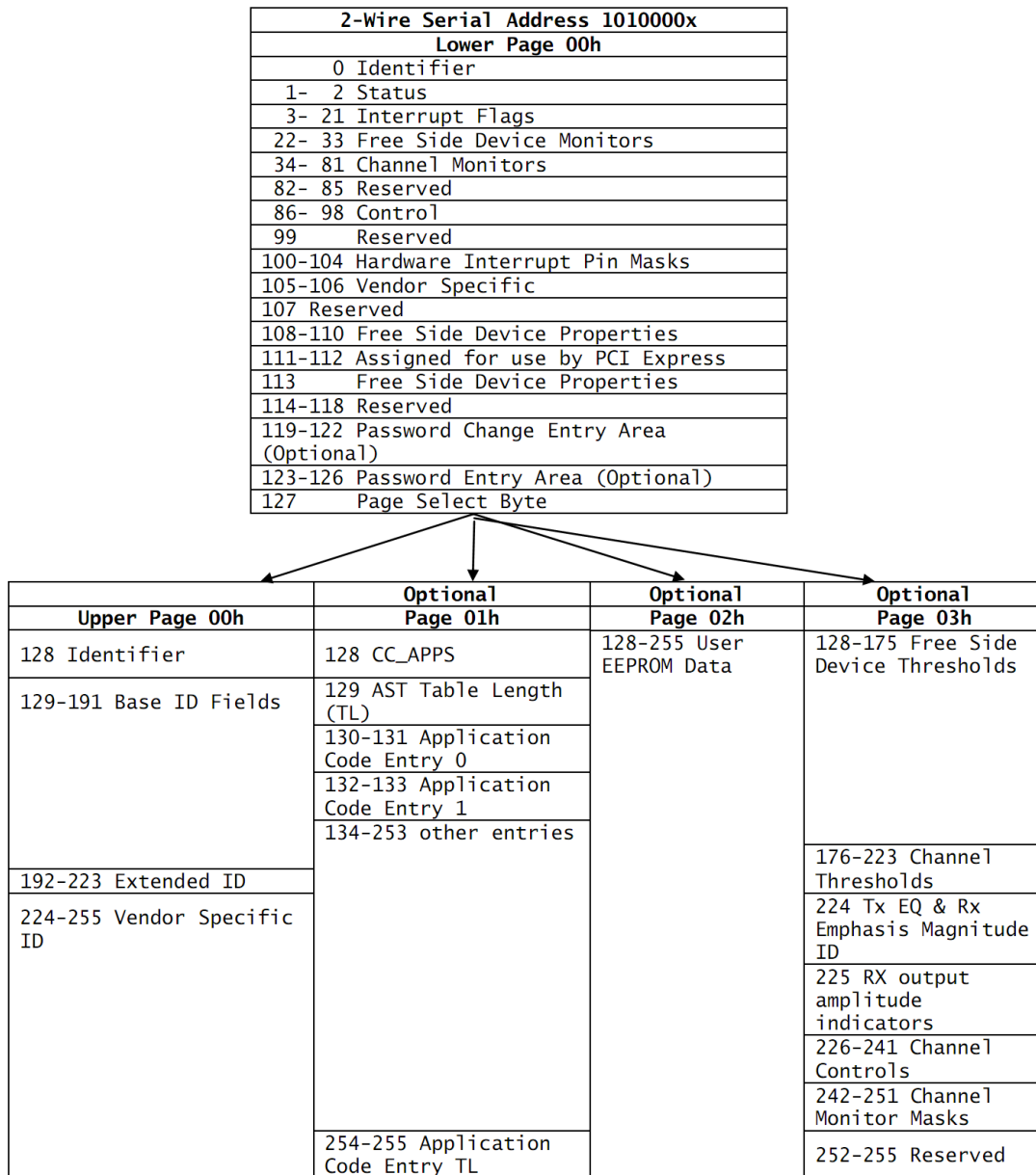

Figure 3, Memory Map

Mechanical Dimensions

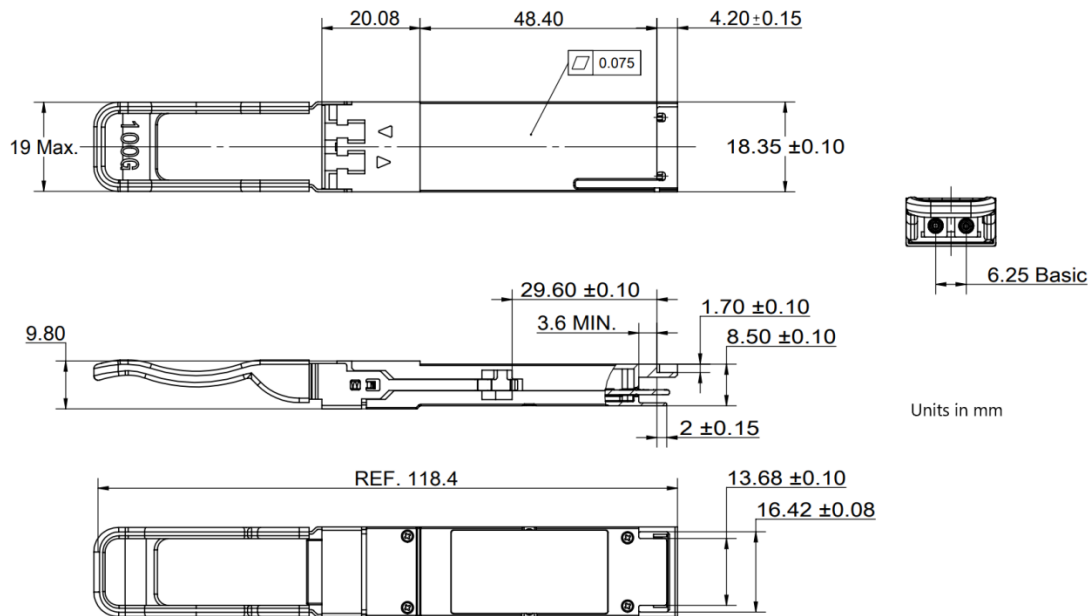

Figure4. Mechanical Outline

Revision History

Version	Initiated	Reviewed	Revision	Release Date
A0	Tony	Jack	New Release	2021-09-09

Warnings

Handling Precautions: This device is susceptible to damage as a result of electrostatic discharge (ESD).

A static free environment is highly recommended. Follow guidelines according to proper ESD procedures.

Laser Safety: Radiation emitted by laser devices can be dangerous to human eyes. Avoid eye exposure to direct or indirect radiation.

Contact Information

Sales@suliton.com